



AUTOMOBIL- UND MOTOREN-WERKE  
BREMEN - GERMANY

## Trunk Lid "Isabella"

**A**  
**216**

Bremen, August 20th, 1957

To our  
Authorized Borgward Dealers and Workshops

Gentlemen:

As is known, the opened trunk lid of our type "Isabella" is held back in its upper position by so-called torsion bar springs. These springs are fitted with initial tension and permit easy opening and closing of the trunk lid.

It now has become apparant that in case of special load of the trunk lid by attachment of lamps, illuminated identification shields etc. the torsion bar springs partly cannot take up this addition of weight. The trunk lid does not remain in opened position then but turns back again.

In such cases this can be easily rectified by fitting of an additional hook on both sides on the supporting brackets for the springs.

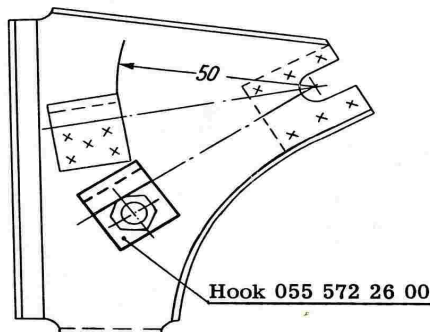

As shown in above drawing the attachment of the hook is made with a bolt, spring washer and nut (M 6) each. For this purpose the supporting brackets must be drilled, which is efficiently done with the aid of a drill extension from the center of the trunk support. The retightening of the torsion bar springs is made by clamping of the offset ends in these hooks.

It is also recommended to make these alterations in case of springs, which have no longer sufficient tension.

Yours very truly,

**CARL F. W. BORGLWARD G. M. B. H.**  
KUNDENDIENST  
(CUSTOMERS SERVICE)  
DEPT.