



CARL F. W. BORGWARD G. M. B. H.  
KUNDENDIENST (CUSTOMERS SERVICE) DEPT.  
AUTOMOBIL- UND MOTOREN-WERKE  
BREMEN - GERMANY

RE.:

## Brake „Isabella“

**B**  
**191**

December 14th, 1956

To all

Authorized Borgward Dealers and Workshops

Dear Sirs,

In some cases it has been ascertained that, conditioned by weather, the Duplex (Two leading shoe) brake of above mentioned type is prone to formation of noise.

Some firms of authorized dealers have tried to rectify this formation of noise by certain repair practices. The attachment of a lead weight to the web of the brake shoe has proved to be the most successful method through which the occurring range of vibration could be shifted advantageously. The lead weight for this, however, must be especially made whereby the shape should approximately correspond with that of the brake shoe. (See figure)

We inform you about this method with all reserve.  
The following working process is essential.

### Removal of Brake Shoes:

1. Lift up car in front, remove wheels.
2. Remove brake drum fillister head bolts, remove brake drums.
3. Remove spring rings on brake armature and remove shims.
4. Remove split pin from eccentric bolt, remove washer.
5. Remove brake shoe tension springs.
6. Turn eccentric bolt outward to highest position.
7. Remove brake shoes.

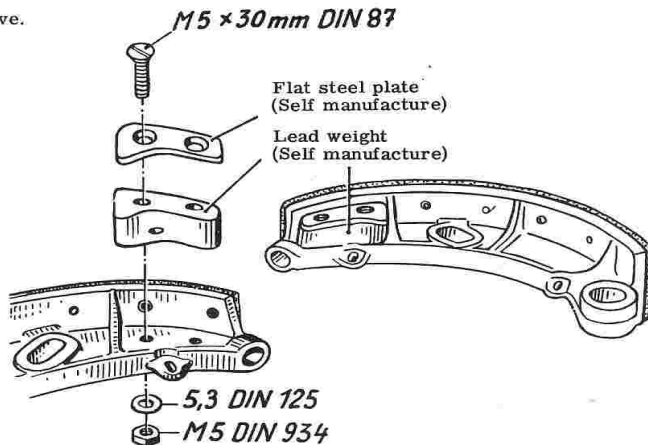

The removed brake shoes are now provided with lead weights of appr. 140 Grams (4.94 ounces (Avoir)) (Casted from lead scrap, old wheel balancing weights etc.) on the outside in the upper part between pressure bolt support and first reinforcement rib and tightened firmly.

In order that the lead weights do not become loose a flat steel plate of the same shape should be used which accommodates the countersunk heads of both bolts. Two c. s. bolts each 5 x 30 mm are used.

It is important that the lead weight to be attached is uniformly and firmly tightened and that washers are placed underneath the nuts. After tightening the hexagonal nuts must be secured by rivet punches.

Yours faithfully

**CARL F. W. BORGWARD G. M. B. H.**

**KUNDENDIENST  
(CUSTOMERS SERVICE)  
DEPT.**

signed Grimberg

signed Wolff