

Body BORGWARD "Isabella"

Eventually existing leakages after body repairs of our type "Isabella" must be rectified as follows:

Water entrance into trunk compartment

1. Check if the rubber profile for the sealing of the trunk compartment is completely and firmly glued on (fig. 1).

Rectification: Glue on rubber profile anew.

2. The sheet metal-U-profile for the support of this rubber seal shows towards the wing side porous holes or cracks (see arrow fig. 1).

Rectification: Smear suspected leaky spots with sealing compound.

3. Water entrance on the roof guttering on the roof by cracking of the burning-off seam (fig. 2). The outlet above the rear left hand side window is especially critical. Smallest porous apertures or cracks in this area can be the cause of water entrance. The water collects then upon the reinforcement plate in the rear upper trunk compartment and flows over from there into the trunk compartment (fig. 3).

Rectification: Remove ornamental batten and weld the suspected leaking spots. Weld autogenous and use the smallest welding burner for sheet metal welding. Cover up the surrounding areas against heat extension by using asbestos plates or pulp soaked in water.

4. Water collects as under position 3 on the rear reinforcement plate in the trunk compartment. Water can enter under the rear parapet batten due to a missing sealing rubber on the holding screws. By removal of the cover plate which is located above the reinforcement plate (with mounted foam rubber) (fig. 3 arrow) the leaky spot can be traced by spraying a water jet on the parapet batten. At the same time observe with the aid of a flashlight where the water enters.

Rectification: Leaky spots are coated from the inside with sealing compound, using a long brush and in case the sealing rubber under the parapet batten is missing, this must be fitted.

5. Water enters into trunk compartment at the cable duct for the brake light (fig. 5).

Rectification: In case that the cable is too tight it must be extended. Seal rubber spout with plastic ribbon or sealing compound.

Water entrance into interior

6. The reasons mentioned under position 3 and 4 for the water entrance into the trunk compartment can also cause a soaking of the roof lining between rear window and rear side window. Furthermore, care must be taken that the rubber profile frame rests properly against body and window. Seal leaky spots with window cement (fig. 6).
7. The cause of a water entrance under the sill batten or the joining carpet can be traced in many cases to a door rubber on the front door pillar which is not properly glued on. Check door rubber.

Rectification: Glue on door rubber or replace if necessary. Drain holes in the doors must be kept open.

8. Water entrance on front wall.
To find the suspected leaky spot in the case of doubt it is recommended to remove the carpet with the felt underneath and to find the suspected leaking spots in the interior by water spraying from the engine compartment. Check especially the lead-in of the
 - a) heater cable
 - b) pedal bracket (fig. 7)
 - c) heating duct (fig. 7 and 8)
 - d) bulkhead plate (spray under wings)
 - e) brackets for accelerator pedal
 - f) flange of the guide tube for hand-brake (fig. 7)
 - g) bearing bracket for bonnet (fig. 8)

Rectification: All above mentioned leakages can be rectified by application of sealing compound!

9. Water entrance on bearing plate for steering on front wall (protecting box) (fig. 9).

Rectification: Remove plate for gearshift in front of covering box and smear plate as well as screws with sealing compound. This water entrance is frequently caused by water dripping from the main harness on to the bearing plate. To prevent this leakage the main harness should sag.

10. The floor plate which rises by steps under the rear seats is spotwelded with a vertical standing sheet metal traverse over the total width of the car. In case that water enters here, the floor mats before the rear seats are wet (fig. 10).

Rectification: The upper joint of both plates below the rear seat is covered with a plastic ribbon. Inside the car the connection of the vertical plate to floor plate is also covered full width with sealing compound. From the bottom side the plate connection in full width must be sealed with sealing compound (also underneath the wings as well as in the corners and at the flange between bearing plate for triangular strut with the cross member). Observe also position 11!

11. Carpet in front of rear seats is wet. Water can enter between the box for the car jack in the sill bracket and connection to cross member (rear) (fig. 11).

Rectification: For this purpose remove rubber plugs from wheel house and apply sealing compound to edges of box for car jack with a long brush.

12. In extreme cases check rubber seal of front wing between door and bonnet which can be pervious to water.

Rectification: Press in plastic ribbon between rubber seal and wind respectively cowl with a wooden edge (fig. 12).

Carl F.W. B o r g w a r d G.m.b.H.
Service Dept. - Technical Service

Bremen, Germany, October 25th, 1960

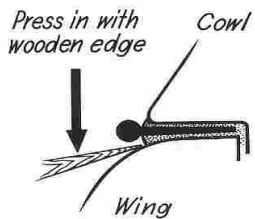

12

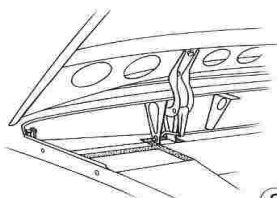

8

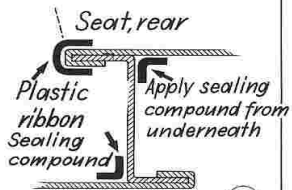

10

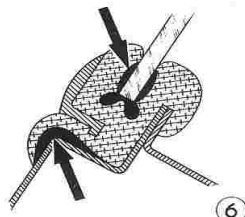
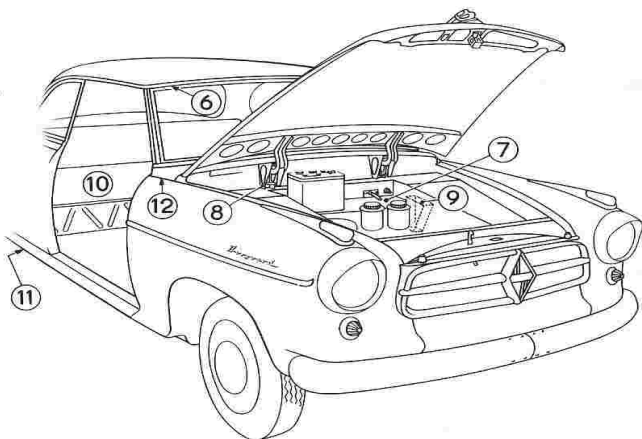

6

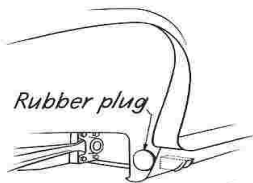

11

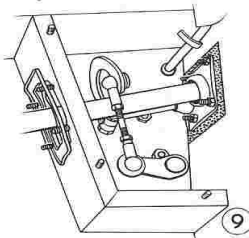

9

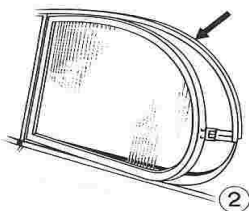

2

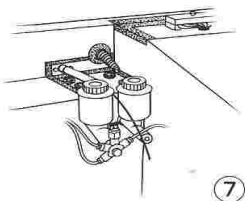
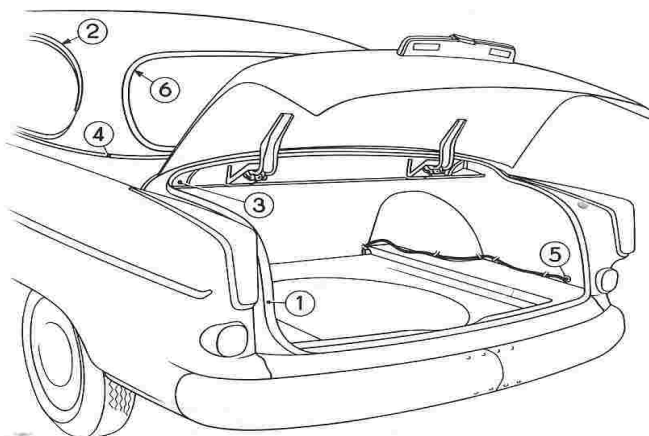

7

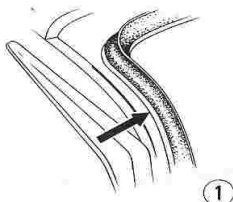

1

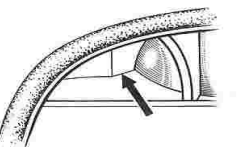

3



4

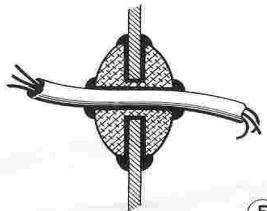

5

Supplement

Body BORGDWARD "Isabella", October 25th, 1960

13. Water entrance at the ends of the foot board batten.

Rectification:

Move carpet bulge a little away from foot board batten and seal corners (see arrow fig. 13) with sealing compound.

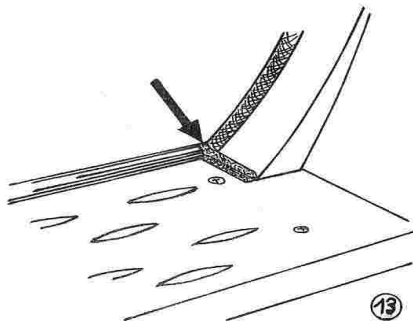

14. Water entrance between door and front wall

- a) - on cable lead-in for interior light.
- b) - on the upper edge between front wall and front wall side part.

Rectification:

- a) Remove bulkhead and fit cable in sagging position.
- b) Smear edges (fig. 14) with sealing compound (supplements pos. 12).

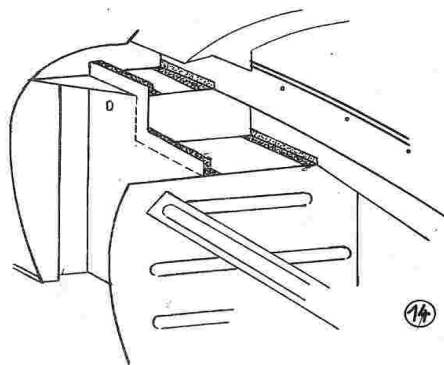

15. Water entrance on front wall (see also pos. 8).

Rectification:

Seal full width of upper flange edge of front wall with sealing compound (fig. 15).

